

Design Analysis & Optimization of an Automotive Disc Brake

G.Ranjith Kumar¹, S.Thriveni², M. Rajasekhar Reddy³, Dr. G. Harinath Gowd⁴

^{1,2}PG Student Department of Mechanical Engineering, Madanapalle Institute of Technology & Science, Madanapalle. Andhra Pradesh., INDIA.

³Assistant Professor, Department of Mechanical Engineering, Madanapalle Institute of Technology & Science, Madanapalle. Andhra Pradesh., INDIA.

⁴Professor, Department of Mechanical Engineering, Madanapalle Institute of Technology & Science, Madanapalle. Andhra Pradesh., INDIA.

Abstract—A brake is a mechanical device which simulated frictional safety is connected to moving machine part, to stop the movement of a machine. At present performing this function, the brakes take in either kinetic energy of the moving part or the potential energy surrendered by items being brought down by lifts and so forth. The energy absorbed by the brakes is scattered as heat. Disc brake is a recognizable car application where they are utilized broadly for car and bike wheels. The disc is sandwiched between two pads activated by cylinders backed in a caliper mounted on the stud shaft. At the point when the brake lever is pressed using pressurized hydraulic pressurized fluid is constrained into the chambers pushing the contradicting cylinders and brake pads into frictional contact with the disc. The frictional heat produced amid braking application can result in various negative impacts on the brake assembly, for example, brake blur, untimely wear, thermal splits and disc thickness variation (DTV). Previously, surface roughness and wear at the pad interface have infrequently been considered in investigations of thermal analysis of a disc brake finite element method. The main purpose of this project is to Optimization of Automotive Brake Disc and analysis the steady state thermal behavior of the dry contact between the brake disc and pads during the braking phase. The thermal-structural analysis to determine the deformation and the Von Misses stresses established in the disc. The objective of the project is the design, analysis and optimization of solid and ventilated disc brake using Solid works, Hyper mesh and Ansys. The ventilated brake disc assembly is built by a 3D model in Solid Works and imported to ANSYS to evaluate the stress fields and of deformations which are established in the disc with the pressure on the pads and in the conditions of tightening of the disc.

Keywords:-Disc Brake, Pads, Ansys, Hyper mesh and Solid Works.

I. INTRODUCTION

A brake is a contact mechanical device for changing over the momentum or kinetic energy of the moving vehicle into heat by method for rubbing. It is obliged to stop or ease off the vehicle in the most brief conceivable separation when needed to do so. Braking of a vehicle relies on the static function that demonstration in the middle of tires and street surface. Brakes take a shot at the following standard to stop the vehicle: "The kinetic energy because of movement of the vehicle is scattered as heat energy because of contact between moving parts (wheel or wheel drum) and stationary parts of the vehicle (brake shoes)". The heat energy so produced because of use of the brakes is dispersed into the air. Brakes work most successfully when they are connected in a way so the wheels don't bolt totally, yet keep on moving without slipping on the surface of the street. The whole time, the brakes take in either kinetic energy of the moving part or the potential energy surrendered by articles being brought down by lifts, and so on. The energy absorbed by the brakes is scattered as heat. This heat is dispersed into the encompassing air to stop the vehicle, so the slowing mechanism ought to have the following prerequisites: 1. The brakes are solid enough to stop the vehicle inside a base Distance. 2. The driver ought to have fitting control over the vehicle amid braking, not to slip. 3. The brakes must have great against blur aspects. 4. The brakes ought to have great against wear properties. In light of mode of operation brakes are named after: Hydraulic brakes, Electric brakes Mechanical brakes. The mechanical brakes are subdivided as per the bearing of acting energy may be the following two assemblies: Radial brakes: The force on the brake drum is in the outspread heading. The outspread brake may be subdivided into outer brakes and inside brakes. Axial brakes: The force on the brake drum is in the hub heading. E.g. Disc brakes, Cone brakes.

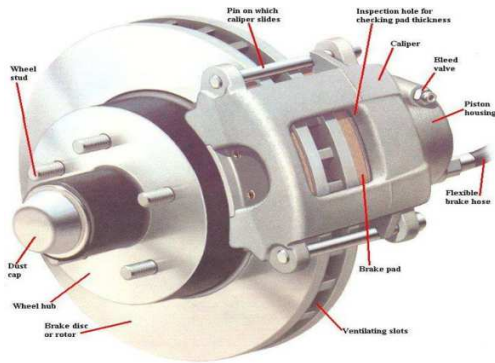

Fig. 1: Disc Brake

a) Disk brakes: A disc brake comprises of an gray cast iron disc darter to the wheel center point and a stationary lodging called a caliper. The caliper is joined with some stationary piece of the vehicle, in the same way as the pivot packaging or the stub hub and is thrown in two sections, each one section holding a cylinder. In the middle of every cylinder and the disc, there is an erosion pad held in position by holding pins, spring discs, and so on sections are penetrated in the caliper for the fluid to enter or leave each one lodging. These entries likewise unite with another for dying. Every chamber holds elastic fixing ring between the barrel and cylinder.

II. MODELLING

Solid Works is solid modeling CAD (computer-aided design) programming that runs on Microsoft Windows and is delivered by Dassault frameworks. Solid Works Corporation was established in December 1993 by Massachusetts Institute of Technology graduate Jon Hirschtick. Jon Hirschtick selected a group of designers to construct an organization that created 3d CAD programming that was not difficult to utilize.

Parameters, suggest to constraints whose qualities focus the shape or geometry of the model or assembly. Parameters could be either numeric parameters, for example, line lengths or disc diameters, or geometric parameters, like digression, parallel, concentric, even or vertical, and so on. Numeric parameters could be connected with one another through the utilization of relations, which permits them to catch design plan.

Features suggest to the building squares of the part. They are the shapes and operations that build the part. Shape-based features normally start with a 2d or 3d sketch of shapes, for example likebosses, holes, slots, etc. This shape is then expelled or slice to include or expel material from the part. Operation-based peculiarities are not portray based,

and incorporate features, for example, filets, chamfers, shells, applying draft to the characteristics of a part, and so forth. Building a model in Solid Works typically begins with a 2d representation.

Here straight vented car disc brake of regular disc brake has been displayed in robust meets expectations.

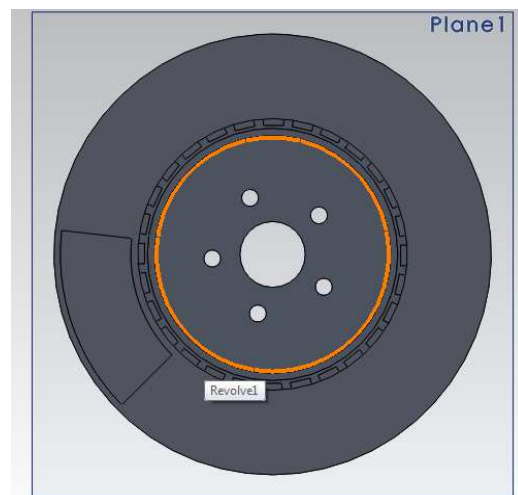

Fig. 2: Front View

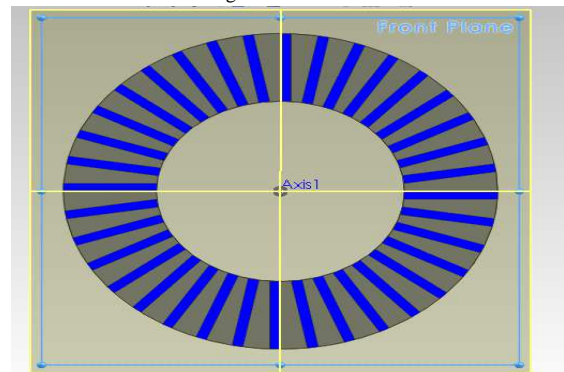

Fig. 3: Sectional View

Based on temperatures & stresses the model has been modified with curved vents. The below figure describes about the modified disc bake.



Fig. 4: Front View

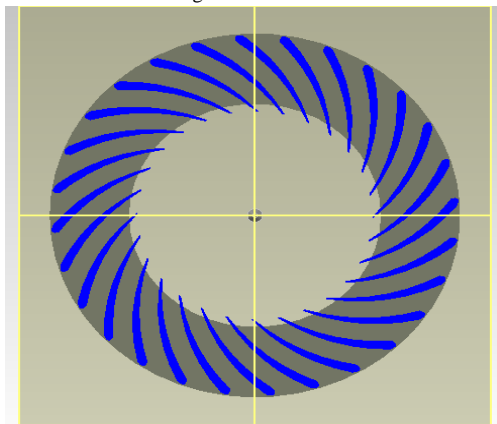

Fig. 5: Sectional View

III. MESHING

Essential subject of FEA is to make calculations at just constrained (Finite) number of focuses & then add the results for whole area (surface or volume). Any ceaseless article has limitless degrees of flexibility & its simply unrealistic to tackle the issue in its configuration. Finite Element Method diminishes degrees of opportunity from Infinite to Finite with the assistance of discretization i.e. fitting (hubs & elements). While doing a analysis, we generally target ideal design, however the systems and apparatuses we use in accomplishing the ideal configuration has any kind of effect. Still, in numerous "spots" the configuration procedure is an experimentation process which relies on upon the determination of the introductory design. This is not an entrenched process as far as how the design advances and relies on upon the engineer's related knowledge. Because of these difficulties arriving at the best plan is not ensured. To defeat these obstructions, numerical optimization is utilized to hunt down and focus the ideal

design. Utilizing the Altair Design Approach, an "idea" improvement step is utilized right on time in the configuration process which conveys an imagined design proposal. The following charts demonstrate the fit group of the brake disc in existing model & proposed model for cast iron.

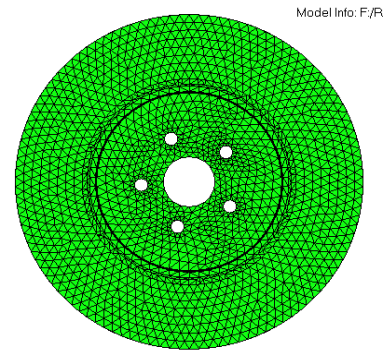

Fig. 8: Existing Model

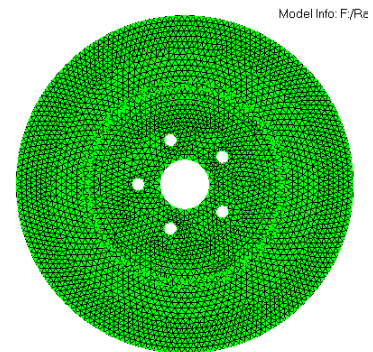

Fig. 9: Proposed Model

IV. ANALYSIS

Dr. John Swanson established ANSYS. Inc in 1970 with a dream to market the idea of workstation reenacted building, creating himself as one of the pioneers of Finite Element Analysis (FEA). ANSYS is universally useful Finite elements analysis (FEA) programming bundle. Finite Element Analysis is a numerical strategy for deconstructing a complex framework into little pieces (of client assigned size) called elements. The product actualizes comparisons that equations the conduct of these elements and unravels all of them; making a complete clarification of how the framework demonstrations all in all. These results then could be displayed in classified or graphical structures.

Table 1. Material Properties

Properties	Cast Iron
Density	7100
Young's Modulus (GPa)	125
Poisson Ratio	0.25
Thermal Conductivity (W/M-K)	54.5
Specific Heat (J/Kg-K)	586
Coefficient of Friction	0.2

V. STEPS IN ANSYS

To take care of any issue in ANSYS it predominantly takes after the following steps. These are normal steps to all issues with the exception of material properties and kind of analysisutilized.

- 1) Preliminary choices: a. Analysis type, b. Model &c. Element type.
- 2) Pre handling: a. Material b. Make or import the model geometry c. Network the geometry
- 3) Solution: a. Apply stacks b. Tackle
- 4) Post preparing: a. Survey results b. Check the legitimacy of the result

Elements considered for Steady State Thermal Analysis:

Here the solid70 elements sort is considered for the Steady State Thermal Analysis. Solid70 has a three-dimensional thermal conduction ability. The elements has eight hubs with a solitary level of opportunity, temperature, at every hub. The elements is relevant to a three-dimensional, consistent state or transient thermal analysis. The elements additionally can adjust for mass transport heat stream from a steady speed field. On the off chance that the model holding the leading robust elements is likewise to be investigated structurally, the elements ought to be supplanted by an identical structural elements, (for example, Solid45). A comparative thermal elements, with mid-edge node function, is explained in Section 4.90 (Solid90).

A choice exists that permits the elements to model nonlinear steady state fluid move through a permeable medium. With this alternative, the thermal parameters are translated as practically equivalent to fluid stream parameters. For instance, the temperature level of opportunity gets to be identical to a weight level of flexibility. See Section 14.70 of the ANSYS Theory Reference for more insights about

these elements. The following table recommends about the properties of cast iron which is existing in the configuration.

VI. RESULTS

An enduring state thermal analysis ascertains the impacts of unflinching thermal loads on a framework or part. Engineer/investigators frequently perform an enduring state investigation before doing a transient thermal analysis, to help create starting conditions.

The system for doing a thermal analysis includes three fundamental errands:

1. Build the model.
2. Apply loads and acquire the result.
3. Audit the results.

Straight vented disc brake:

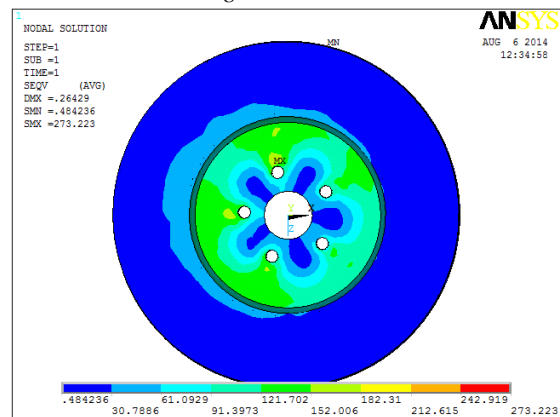

Fig.10:

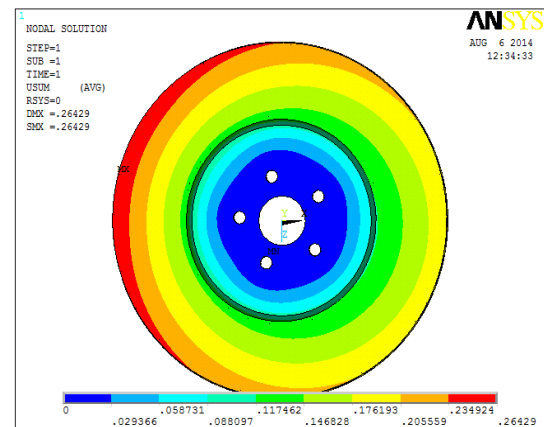
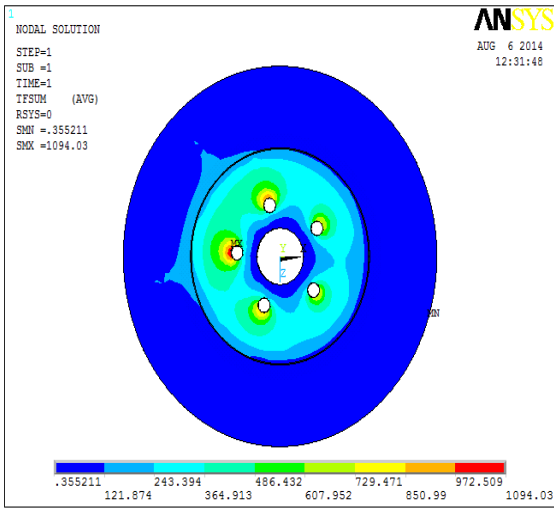
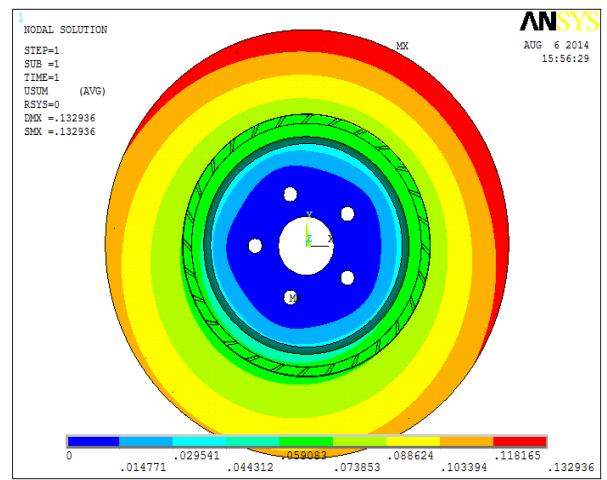

Fig.11:



Thermal Flux Vector Sum

Fig. 12:



Displacement Vector Sum

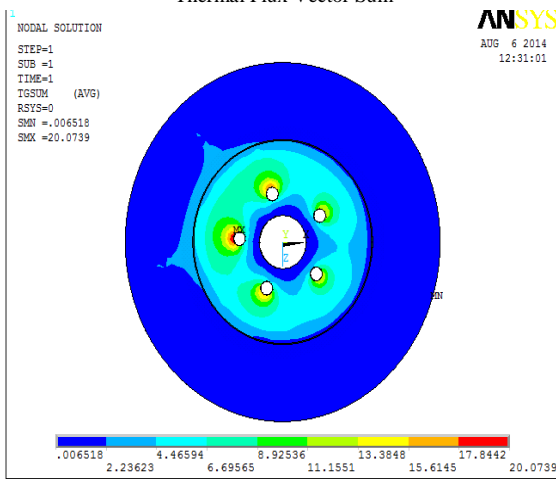

Thermal Gradient Vector Sum
Curved vented disc brake:

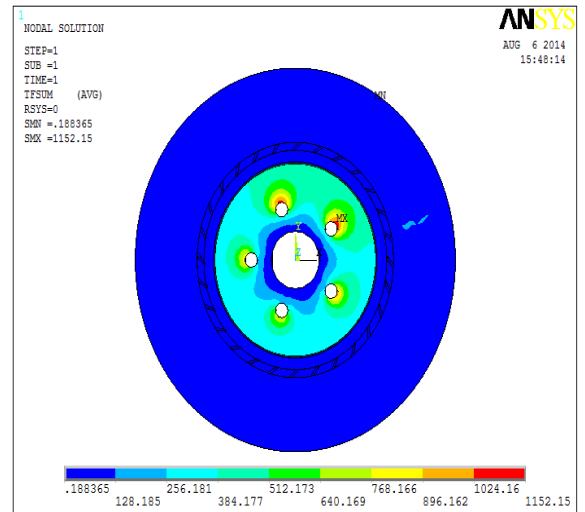

Thermal Flux Vector Sum

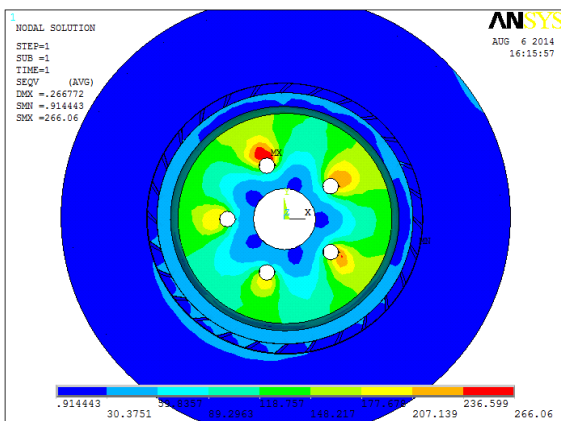

VonMisesStresses

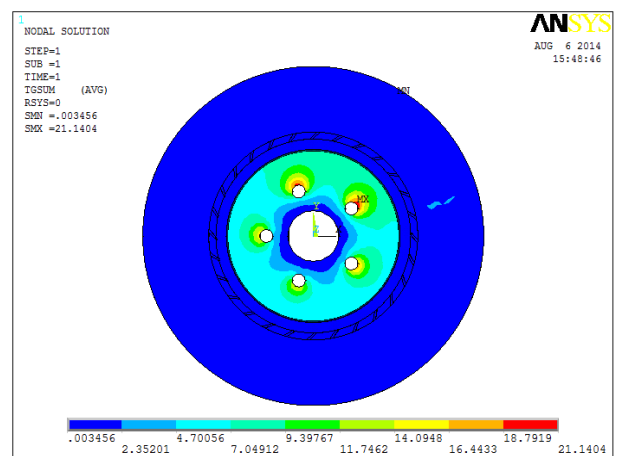

Thermal Gradient Vector Sum

Table 2. Results Comparison

RESULTS	EXISTING MODEL	PROPOSED MODEL
Von misses stresses	273.223	266.06
Displacement vector sum	0.26429	0.13293
Thermal flux vector sum	1094.03	1152.15
Thermal gradient vector sum	20.739	21.1404
Mass	2.7904kg	2.6829kg

The table illustrates the results of existing & proposed model steady state thermal analysis. By these we can easily find out that the curved vented disc brake has the low thermal flux compared to the straight vented disc brake.

VII.CONCLUSION

This paper explains about the design of a straight & vented brake discs in Solid Works. It also includes the deck preparation in hyper mesh, i.e., meshed part with applying the temperatures. Finally both the brake discs are been analyzed in Ansys for the Steady Static Thermal analysis. In these results, we get that, by changing the straight vents to curved vents in the brake disc the vonmises stresses & displacement vector sum & mass of the brakes disc has been reduced. And also curved vented brake disc is generated a high thermal flux than a straight vented brake disc.

REFERENCES

- [1] Finite Element Analysis for Engineering &Tech. Author, T.Chandraputla. Edition, illustrated. Publisher, Universities Press, 2004.ISBN, 8173714274
- [2] Machine Design Edition: 14th. Author: R.S. Khurmi& J.K. Gupta
- [3] V. Chengal Reddy, M. Gunasekhar Reddy, Dr. G. Harinath Gowd “ Modeling And Analysis of FSAE Car Disc Brake Using FEM” International Journal of Emerging Technology and Advanced Engineering, ISSN 2250-2459, ISO 9001:2008 Certified Journal, Volume 3, Issue 9, September 2013.
- [4] Manjunath T V, Dr Suresh P M “Structural and Thermal Analysis of Rotor Disc of Disc Brake” An ISO 3297: 2007 Certified Organization, Vol. 2, Issue 8, August 2013
- [5] Ameer FareedBasha Shaik1, Ch.LakshmiSrinivas., “Structural and Thermal Analysis of Disc Brake with and without cross drilled rotor of race car”, International Journal of Advanced Engineering Research and Studies, Vol. 1/ Issue IV/July-Sept.,2012/39-43, India.
- [6] AliBelhocine, MostefaBouchetara. Thermal analysis of a solid brake disc, Applied Thermal Engineering 32 (2012) 59-67.
- [7] Guru Murthy Nathil, T N Charyulu, “Coupled Structural/ Thermal Analysis of Disc Brake” IJRET, Vol.2, PP 539-553, 2012.

[8] First Edition of “Practical Finite Element Analysis” by Nitin S Gokhale, Sanjay S Deshpande, Sanjeev v Bhedekar, Anand N Thite.